

(19) World Intellectual Property
Organization
International Bureau



(43) International Publication Date
31 March 2005 (31.03.2005)

PCT

(10) International Publication Number
WO 2005/028086 A1

- (51) International Patent Classification⁷: **B01D 65/02**
- (21) International Application Number: PCT/AU2004/001292
- (22) International Filing Date: 22 September 2004 (22.09.2004)
- (25) Filing Language: English
- (26) Publication Language: English
- (30) Priority Data: 2003905174 22 September 2003 (22.09.2003) AU
- (71) Applicant (for all designated States except US): **U.S. FILTER WASTEWATER GROUP, INC.** [US/US]; 181 Thorn Hill Road, Warrendale, PA 15086 (US).
- (72) Inventor; and
- (75) Inventor/Applicant (for US only): **JOHNSON, Warren, Thomas** [AU/AU]; 125 Grose Vale Road, Grose Vale, NSW 2753 (AU).
- (74) Agent: **SHELSTON IP**; 60 Margaret Street, Sydney, NSW 2000 (AU).
- (81) Designated States (unless otherwise indicated, for every kind of national protection available): AE, AG, AL, AM, AT, AU, AZ, BA, BB, BG, BR, BW, BY, BZ, CA, CH, CN, CO, CR, CU, CZ, DE, DK, DM, DZ, EC, EE, EG, ES, FI, GB, GD, GE, GH, GM, HR, HU, ID, IL, IN, IS, JP, KE, KG, KP, KR, KZ, LC, LK, LR, LS, LT, LU, LV, MA, MD, MG, MK, MN, MW, MX, MZ, NA, NI, NO, NZ, OM, PG, PH, PL, PT, RO, RU, SC, SD, SE, SG, SK, SL, SY, TJ, TM, TN, TR, TT, TZ, UA, UG, US, UZ, VC, VN, YU, ZA, ZM, ZW.
- (84) Designated States (unless otherwise indicated, for every kind of regional protection available): ARIPO (BW, GH, GM, KE, LS, MW, MZ, NA, SD, SL, SZ, TZ, UG, ZM, ZW), Eurasian (AM, AZ, BY, KG, KZ, MD, RU, TJ, TM), European (AT, BE, BG, CH, CY, CZ, DE, DK, EE, ES, FI, FR, GB, GR, HU, IE, IT, LU, MC, NL, PL, PT, RO, SE, SI, SK, TR), OAPI (BF, BJ, CF, CG, CI, CM, GA, GN, GQ, GW, ML, MR, NE, SN, TD, TG).
- Declaration under Rule 4.17:**
— of inventorship (Rule 4.17(iv)) for US only
- Published:**
— with international search report

[Continued on next page]

(54) Title: BACKWASH AND CLEANING METHOD

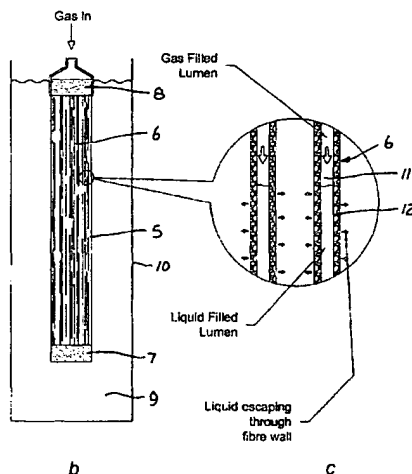

(57) Abstract: A method of concentrating the solids of a liquid suspension by providing a pressure differential across the walls of permeable, hollow membranes (6) immersed in the liquid suspension (9). The liquid suspension (9) is applied to the outer surface of the porous hollow membranes (6) to induce and sustain filtration through the membrane walls (12) wherein some of the liquid suspension passes through the walls (12) of the membranes (6) to be drawn off as clarified liquid or permeate from the hollow membrane lumens (11), and at least some of the solids are retained on or in the hollow membranes (6) or otherwise as suspended solids within the liquid (9) surrounding the membranes (6). The method includes periodically backwashing the membrane pores using the permeate by applying a gas at a pressure below the bubble point to the membrane lumens (11) to progressively displace at least some of the liquid permeate within the lumens (11) through the membrane pores resulting in removal the solids retained on or in the hollow membranes into the bulk liquid (9) surrounding the membranes (6).

WO 2005/028086 A1



For two-letter codes and other abbreviations, refer to the "Guidance Notes on Codes and Abbreviations" appearing at the beginning of each regular issue of the PCT Gazette.

- 1 -

Backwash and Cleaning Method

FIELD OF THE INVENTION

The present invention relates to concentration of solids in a suspension
5 using hollow fibre membranes and, in particular, to an improved method of
backwashing and chemically cleaning the hollow fibre membranes.

BACKGROUND ART

Any discussion of the prior art throughout the specification should in no
way be considered as an admission that such prior art is widely known or forms
10 part of common general knowledge in the field.

Known backwash systems include those described in our earlier
International Application No. WO93/02779 the subject matter of which is
incorporated herein by cross-reference.

A pressurized liquid backwash of hollow fibre membranes has been found
15 to be uneven along the length of the fibre membranes due to the frictional
losses along the lumen. In membranes with the fibres closed at one end, the
pressure of liquid is highest at the point of application of the pressurized flow to
the fibres lumens and tapering off along the length of the membrane. This
results in uneven backwashing and poor recovery of TMP at portions of the
20 fibres remote from the backwash application point. In fibres open at both ends,
the backwash flow is a minimum towards the centre of the fibre.

During chemical cleaning of membranes, cleaning solutions are often
backflushed from the lumen side of the membrane to distribute the cleaning
solution within the membrane fibre bundle. Applying the cleaning solution under
25 pressure assists the removal of foulants from the surface. However, the

- 2 -

limitations of pressure drop down the lumen during this step mean that achieving the same applied transmembrane pressure (TMP) to all areas of the membrane cannot be readily achieved, especially for small diameter fibres where the pressure loss is greatest. This impacts on the efficiency of cleaning.

5 DISCLOSURE OF THE INVENTION

It is an object of the invention to overcome or at least ameliorate one or more of the disadvantages of the prior art or at least provide a useful alternative.

According to a first aspect, the present invention provides a method of concentrating the solids of a liquid suspension comprising:

- 10 (i) providing a pressure differential across the walls of permeable, hollow membranes immersed in the liquid suspension, said liquid suspension being applied to the outer surface of the porous hollow membranes to induce and sustain filtration through the membrane walls wherein:
- (a) some of the liquid suspension passes through the walls of the
15 membranes to be drawn off as clarified liquid or permeate from the hollow membrane lumens, and
- (b) at least some of the solids are retained on or in the hollow membranes or otherwise as suspended solids within the liquid surrounding the membranes,
- 20 (ii) periodically backwashing the membrane pores using the permeate by applying a gas at a pressure below the bubble point to the membrane lumens to progressively displace at least some of the liquid permeate within the lumens through the membrane pores resulting in removal the solids retained on or in the hollow membranes into the bulk liquid surrounding the membranes.

- 3 -

This process ensures that the differential pressure applied during backwash is close to the gas pressure at the liquid interface as it travels down the lumen thereby ensuring that the maximum differential pressure is applied across the membrane wall at all points, although not simultaneously.

5 According to a second aspect, the present invention provides a method of concentrating the solids of a liquid suspension comprising:

(i) providing a pressure differential across the walls of permeable, hollow membranes immersed in the liquid suspension, said liquid suspension being applied to the outer surface of the porous hollow membranes to induce
10 and sustain filtration through the membrane walls wherein:

(a) some of the liquid suspension passes through the walls of the membranes to be drawn off as clarified liquid or filtrate from the hollow membrane lumens, and

(b) at least some of the solids are retained on or in the hollow
15 membranes or otherwise as suspended solids within the liquid surrounding the membranes,

(ii) dislodging the retained solids from the membranes by applying a dislodging medium through the lumens of said membranes while concurrently draining liquid from said lumens, wherein the application of the dislodging
20 medium initially displaces liquid within the hollow membrane lumens through the hollow membrane with gas, to effect firstly a discharge of liquid in the lumens through the membrane walls, and secondly a transmembrane cleaning of the membranes by applying the gas at sufficient pressure onto the liquid to overcome the bubble point of the membrane, and ensure that the gas will
25 displace liquid and follow it through the larger pores of the membranes to

- 4 -

dislodge any solids retained therein; and for the emerging gas to scour the external walls of the membranes and displace the removed solids into the bulk liquid surrounding the membranes.

Preferably, said method is carried out as a continuous process utilising a
5 repetitive cycle of solid accumulation and solid discharge.

According to a third aspect the present invention provides a concentrator for recovering fine solids from a liquid feed suspension comprising:

- (i) a vessel for containing said feed suspension;
- (ii) a plurality of permeable, hollow membranes within the vessel;
- 10 (iii) means for providing a pressure differential across walls of said membranes;
- (iv) means for withdrawing clarified liquid from the membrane; and
- (v) means for applying gas at a pressure below the bubble point to the liquid permeate in the membrane lumens to effect a discharge of at least some
15 of the liquid permeate in the lumens through the membrane walls to dislodge any solids retained therein and displace the removed solids into the bulk liquid surrounding the membranes.

According to a fourth aspect the present invention provides a concentrator for recovering fine solids from a liquid feed suspension comprising:

- 20 (i) a vessel or tank for containing said feed suspension;
- (ii) a plurality of permeable, hollow membranes within the vessel or tank;
- (iii) means for providing a pressure differential across walls of said membranes;
- 25 (iv) means for withdrawing clarified liquid from the membrane; and

- 5 -

(v) means for applying gas pressure to the liquid in the membrane lumens and walls while the vessel or tank is exposed to atmospheric pressure and while concurrently draining liquid from said lumens, to effect firstly a discharge of liquid in the lumens through the membrane walls, and secondly a transmembrane cleaning of the membranes by applying the gas at sufficient pressure onto the liquid to overcome the bubble point of the membrane, and ensure that the gas will displace liquid and follow it through the larger pores of the membranes to dislodge any solids retained therein; and for the emerging gas to scour the external walls of the membranes and displace the removed solids into the bulk liquid in the vessel or tank.

Preferably, the backwash includes use of clean-in-place (CIP) chemical solutions as well as or instead of the filtrate. This may be employed in a number of different backwash methods.

One such backwash method includes filtering the chemical cleaning solution from the shell side, that is, from the outer surface or vessel side of the membrane into the membrane lumens. The normal backwash is then performed and the chemical solution forced back through the membrane pores in an even fashion by applying a gas as described above.

Another alternate form of chemical backwash includes backwashing initially with filtrate, that is, pushing the filtrate in a reverse direction through the membrane pores while injecting chemical cleaning solution into the filtrate. The filtrate/chemical solution mixture is then backwashed through the membrane by applying a gas as described above.

Yet another alternate form of chemical backwash includes applying chemical cleaning solution under pressure to the outer side of the membranes

- 6 -

to force chemical cleaning solution through the membrane pores and fill the membrane lumens with the chemical cleaning solution. This is followed by the normal gas backwash described above.

In order to minimise the volume of chemical cleaning solution used all (or
5 most) of the liquid in the system may be removed or drained from one side of the membrane, typically the filtrate side (or inside of the hollow membrane), then the outer side of the membrane is at least partially filled with chemical cleaning solution and a vacuum (or reduced pressure) applied to the filtrate side to cause the chemical cleaning solution to be drawn from the outer side of the membrane
10 to the filtrate side, then gas pressure is applied to the filtrate side to force the chemical cleaning solution in the reverse direction from the filtrate side through the membrane wall back to the outer side of the membrane.

In another method, the filtrate side of the membrane(s) is drained or emptied of liquid and liquid on the outer side of the membranes is also partially
15 drained or emptied. The outer side of the membrane lumen is then at least partially filled chemical cleaning solution. The chemical cleaning solution applied to the outer side of the membranes is then pushed through with gas (for a pressurized system) or drawn through under suction (for a submerged non-pressurized system) to fill the lumen with chemical cleaning solution and the
20 volume of chemical cleaning solution used is less than the hold-up volume of liquid on the outer side of the membranes. Only enough volume of chemical cleaning solution on the outer side of the membranes to fill the membrane lumens is required. Pressure can then be applied to the lumen side to drain the chemical cleaning solution from the lumen by pushing it back through the
25 membrane wall. This cycle can be repeated multiple times so that the chemical

- 7 -

cleaning solution is alternately moved from one side of the membrane to the other through the membrane wall.

Each of the above chemical cleaning methods has been found to provide a more efficient chemical backwash. The methods allow for a minimal use of
5 chemical cleaning solution while also enabling an enhanced washing process by providing a more efficient distribution of the chemical cleaning solution within the system. Desirably, these backwashes or cleans are performed on an intermittent basis.

Using the methods described the reverse flow cleaning step can be
10 accomplished in such a way as to allow the transmembrane pressure (TMP) to be controlled by the gas pressure and to apply this TMP evenly along the membrane, even at the extremities from the lumen inlet. This ensures all areas of the membrane are contacted with chemical cleaning solution and that they are back-flushed with the same applied TMP. It also allows the chemical in the
15 lumens to be fully drained by the end of the reverse flow step, which aids in recovery of chemical cleaning solution, reduces flushing requirements, and reduces cleaning downtime.

In one preferred form, the gas may be pulsed in its application to the membrane lumens. In one alternate form of the chemical solution backwash
20 described above, the backwash is performed with the vessel empty.

The process can be applied to membranes submerged in an open vessel as well as pressurized membrane filtration systems.

BRIEF DESCRIPTION OF THE DRAWINGS

Preferred embodiments of the invention will now be described, by way of
25 example only, with reference to the accompanying drawings in which:

Figure 1a shows a graph of transmembrane pressure (TMP) vs position along the membrane bundle of the membrane module configuration shown in Figure 1b;

Figure 1b shows a simplified sectional side elevation of a membrane module immersed in a feed liquid with pressurized liquid applied to the membrane lumens;

Figure 2a shows a graph of transmembrane pressure (TMP) vs position along the membrane bundle of the membrane module configuration shown in Figure 2b;

Figure 2b shows a simplified sectional side elevation of a membrane module immersed in a feed liquid with pressurized gas applied to the membrane lumens;

Figure 3a shows a graph of transmembrane pressure (TMP) vs position along the membrane bundle of the membrane module configuration shown in Figure 3b;

Figure 3b shows a simplified sectional side elevation of a membrane module immersed in a feed liquid with pressurized gas applied to liquid filled membrane lumens;

Figure 3c shows an enlarged sectional view of the membranes in the indicated region of Figure 3b;

Figure 4a shows a simplified sectional side elevation of a membrane module with the feed liquid drained from around the module;

Figure 4b shows an enlarged sectional view of the membranes in the indicated region of Figure 4b;

- 9 -

Figure 5a shows a simplified sectional side elevation of a membrane module with a lower portion of the module immersed in a chemical cleaning solution and suction applied to the membrane lumens;

Figure 5b shows an enlarged sectional view of the membranes in the indicated region of Figure 5a;

Figure 5c shows an enlarged sectional view of the membranes in the indicated region of Figure 5a;

Figure 6a shows a simplified sectional side elevation of a membrane module with a lower portion of the module immersed in a chemical cleaning solution and pressurized gas applied to the membrane lumens; and

Figure 6b shows an enlarged sectional view of the membranes in the indicated region of Figure 6a.

DESCRIPTION OF PREFERRED EMBODIMENTS

Referring to Figures 1a and 1b, the graph shown in Figure 1a illustrates the change in transmembrane pressure (TMP) as the distance from the application of pressure flow increases. Figure 1b shows a membrane module having a plurality of hollow fibre membranes 6. The fibre membranes 6 are closed at the lower end in a lower pot 7 and open at the upper end through upper pot 8. The module is immersed in liquid 9 contained in a vessel 10. In the case illustrated, pressurized liquid is applied to the open end of the fibre lumens 11 resulting in the TMP profile shown in Figure 1a.

As noted above, in membranes with the fibre membranes 6 closed at one end, the pressure of liquid is highest at the point of application of the pressurized flow to the fibres lumens 11 and tapers off along the length of the

- 10 -

membrane 6. This results in uneven backwashing and poor recovery of TMP at portions of the fibre membranes 6 remote from the backwash application point.

Figures 2a and 2b show a similar arrangement to Figure 1 but in this case pressurized gas is applied to the fibre membrane lumens 11 resulting in an even
5 distribution of TMP along the length of the fibre membranes 6.

Figures 3a to 3c illustrate one embodiment of the invention where pressurized gas is applied at a pressure below the bubble point to liquid filled fibre membrane lumens 11. As best shown in Figure 3c as the liquid is displaced through the membrane wall 12, the lumen 11 becomes filled with gas
10 resulting in a maximum TMP being applied along the length of the fibre membrane 6 as the liquid level within the fibre membrane lumen 11 drops.

Figure 4a and 4b illustrate a further embodiment of the invention where liquid is drained from around the membrane module 5 before the backwashing process is commenced. The backwashing process is similar to that described
15 above for Figure 3.

Referring to Figures 5 and 6, one embodiment of the cleaning process according to the invention is illustrated. The membrane module 5 is immersed at least partially in chemical cleaning solution 13 and suction is applied to the open ends of the fibre membrane lumens 11. As best shown in figure 5b, the
20 cleaning solution 13 is drawn through the membrane wall 12 and into the fibre membrane lumen 11. The cleaning solution 13 is then drawn up through the lumen 11 until it is completely filled as shown in Figure 5c. As shown in Figures 6a and 6b, pressurized gas is then applied to the cleaning solution filling the membrane lumen 11 and displaced through the membrane wall 12 as previously
25 described. This flow of cleaning solution to and from the membrane lumens 11

- 11 -

as well as along their length results in an effective chemical clean of the membrane module 5.

The invention may be embodied in a similar apparatus to that described in the aforementioned International Application No. WO93/02779 appropriately
s modified to operate in accordance with the inventive method.

It will be appreciated that further embodiments and exemplifications of the invention are possible without departing from the spirit or scope of the invention described.

CLAIMS:

1. A method of concentrating the solids of a liquid suspension comprising:
 - (i) providing a pressure differential across the walls of permeable, hollow membranes immersed in the liquid suspension, said liquid suspension
5 being applied to the outer surface of the porous hollow membranes to induce and sustain filtration through the membrane walls wherein:
 - (a) some of the liquid suspension passes through the walls of the membranes to be drawn off as clarified liquid or filtrate from the hollow membrane lumens, and
 - 10 (b) at least some of the solids are retained on or in the hollow membranes or otherwise as suspended solids within the liquid surrounding the membranes,
 - (ii) periodically backwashing the membrane pores using the filtrate by applying a gas at a pressure below the bubble point to the membrane lumens to
15 progressively displace at least some of the liquid filtrate within the lumens through the membrane pores resulting in removal the solids retained on or in the hollow membranes into the bulk liquid surrounding the membranes.
2. A method of concentrating the solids of a liquid suspension comprising:
 - (i) providing a pressure differential across the walls of permeable,
20 hollow membranes immersed in the liquid suspension, said liquid suspension being applied to the outer surface of the porous hollow membranes to induce and sustain filtration through the membrane walls wherein:
 - (a) some of the liquid suspension passes through the walls of the membranes to be drawn off as clarified liquid or filtrate from the
25 hollow membrane lumens, and

- 13 -

- (b) at least some of the solids are retained on or in the hollow membranes or otherwise as suspended solids within the liquid surrounding the membranes,
- (ii) dislodging the retained solids from the membranes by applying a
- 5 dislodging medium through the lumens of said membranes while concurrently draining liquid from said lumens, wherein the application of the dislodging medium initially displaces liquid within the hollow membrane lumens through the hollow membrane with gas, to effect firstly a discharge of liquid in the lumens through the membrane walls, and secondly a transmembrane cleaning of the
- 10 membranes by applying the gas at sufficient pressure onto the liquid to overcome the bubble point of the membrane, and ensure that the gas will displace liquid and follow it through the larger pores of the membranes to dislodge any solids retained therein; and for the emerging gas to scour the external walls of the membranes and displace the removed solids into the bulk
- 15 liquid surrounding the membranes.
3. A method of concentrating the solids of a liquid suspension according to claim 1 or 2 wherein said method is carried out as a continuous process utilising a repetitive cycle of solid accumulation and solid displacement or removal.
4. A method of concentrating the solids of a liquid suspension according to
- 20 any one of the preceding claims wherein the dislodging or backwashing step includes use of a chemical cleaning solution.
5. A method of concentrating the solids of a liquid suspension according to claim 4 including the step of filtering the chemical cleaning solution from the outer surface of the porous hollow membranes into the membrane lumens. and

- 14 -

then displacing said chemical cleaning solution back through the membrane pores by application of said gas.

6. A method of concentrating the solids of a liquid suspension according to claim 4 wherein the backwashing or dislodging step includes displacing the
5 filtrate in a reverse direction through the membrane pores while injecting chemical cleaning solution into the filtrate.
7. A method of concentrating the solids of a liquid suspension according to claim 4 including the step of applying chemical cleaning solution under pressure to the outer surface of the porous hollow membranes to displace chemical
10 cleaning solution through the membrane pores into the membrane lumens and then displacing said chemical cleaning solution back through the membrane pores by application of said gas.
8. A method according to any one of claims 5 to 7 when appended to claim 1 including the step of removing at least part of the liquid remaining in the
15 membrane lumens prior to displacing chemical cleaning solution into the membrane lumens.
9. A method according to any one of claims 5 to 7 when appended to claim 2 wherein the displacing of chemical solution into the membrane lumens takes place before said transmembrane cleaning.
- 20 10. A method of concentrating the solids of a liquid suspension according to any one of the preceding claims wherein the gas is pulsed in its application to the membrane lumens.
11. A method of concentrating the solids of a liquid suspension according to any one of the preceding claims including the step of removing at least part of

the bulk liquid surrounding the membranes prior to the backwashing or dislodging step.

12. A concentrator for recovering fine solids from a liquid feed suspension comprising:

- 5 (i) a vessel for containing said feed suspension;
- (ii) a plurality of permeable, hollow membranes within the vessel;
- (iii) means for providing a pressure differential across walls of said membranes;
- (iv) means for withdrawing clarified liquid from the membrane; and
- 10 (v) means for applying gas at a pressure below the bubble point to the liquid permeate in the membrane lumens to effect a discharge of at least some of the liquid permeate in the lumens through the membrane walls to dislodge any solids retained therein and displace the removed solids into the bulk liquid surrounding the membranes.

15 13. A concentrator for recovering fine solids from a liquid feed suspension comprising:

- (i) a vessel or tank for containing said feed suspension;
- (ii) a plurality of permeable, hollow membranes within the vessel or tank;
- 20 (iii) means for providing a pressure differential across walls of said membranes;
- (iv) means for withdrawing clarified liquid from the membrane; and
- (v) means for applying gas pressure to the liquid in the membrane lumens and walls while the vessel or tank is exposed to atmospheric pressure
- 25 and while concurrently draining liquid from said lumens, to effect firstly a

- 16 -

discharge of liquid in the lumens through the membrane walls, and secondly a transmembrane cleaning of the membranes by applying the gas at sufficient pressure onto the liquid to overcome the bubble point of the membrane, and ensure that the gas will displace liquid and follow it through the larger pores of
5 the membranes to dislodge any solids retained therein; and for the emerging gas to scour the external walls of the membranes and displace the removed solids into the bulk liquid in the vessel or tank.

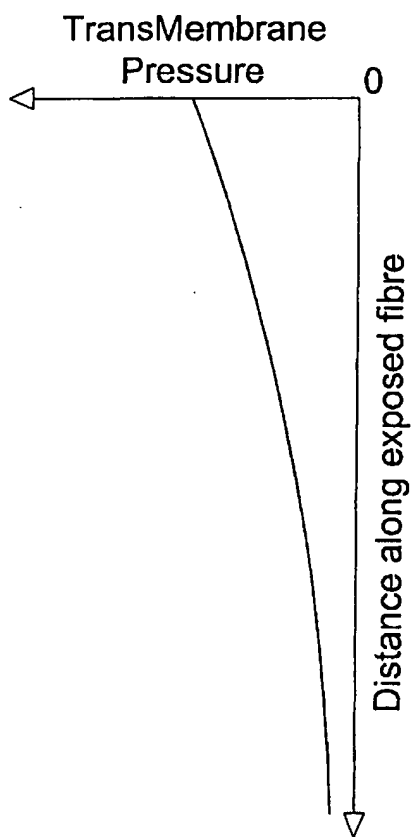

Fig. 1a

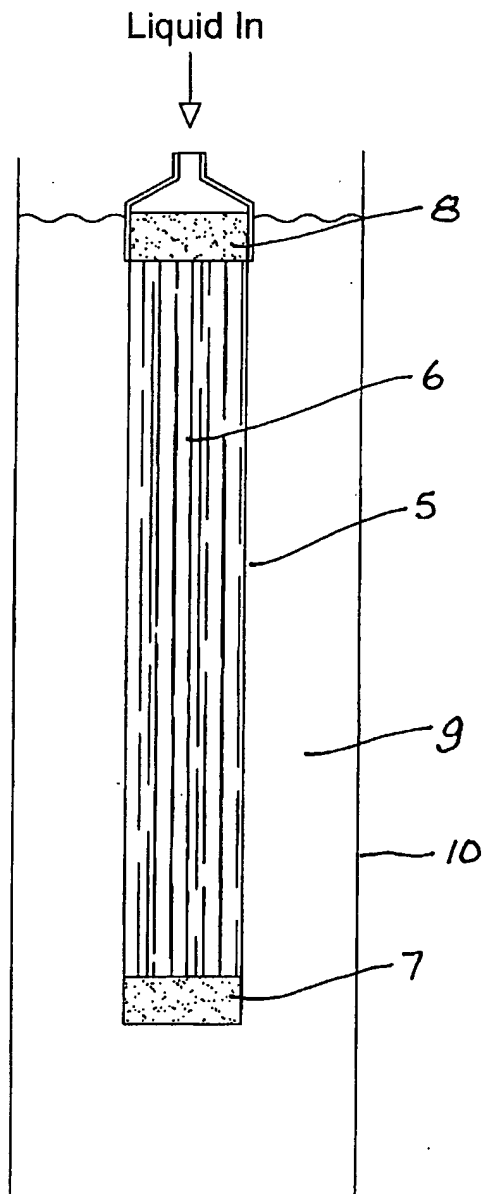

Fig. 1b

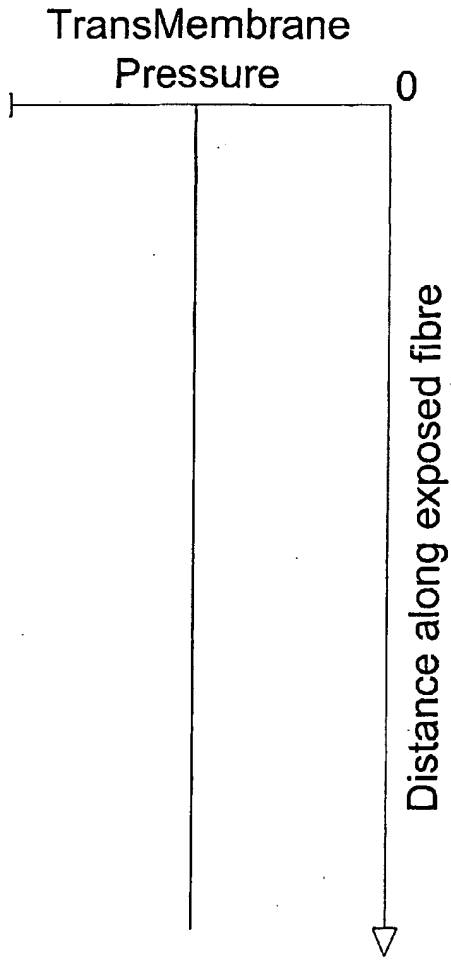

Fig. 2a

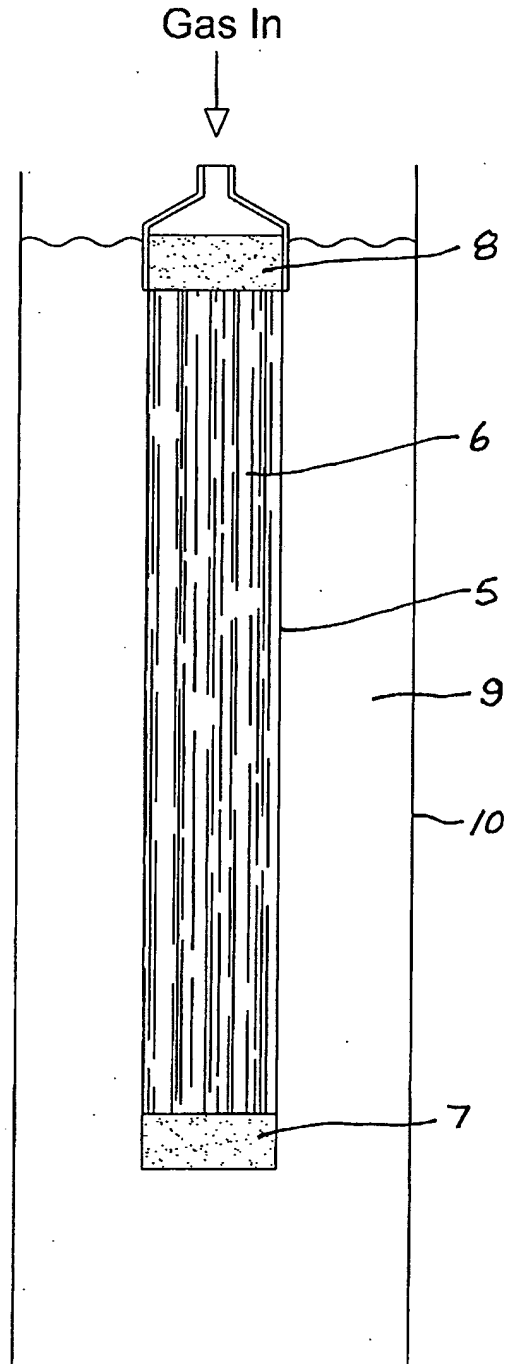

Fig. 2b

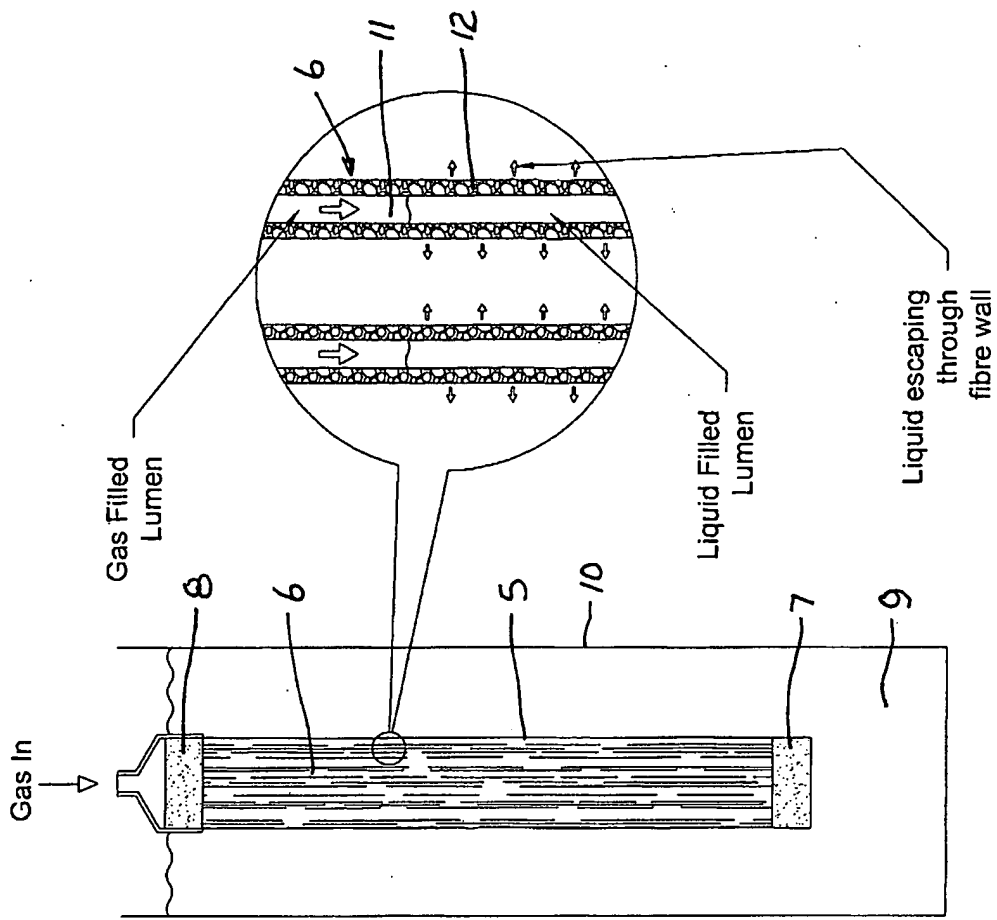

Fig. 3c

Fig. 3b

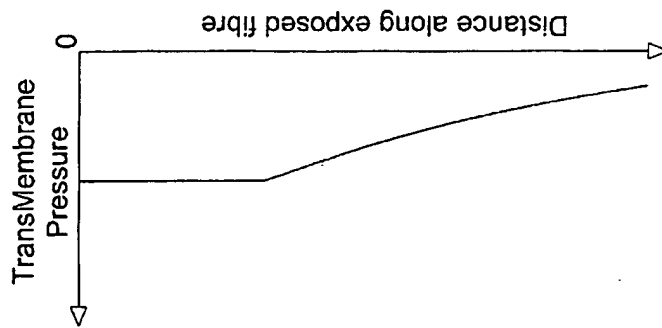

Fig. 3a

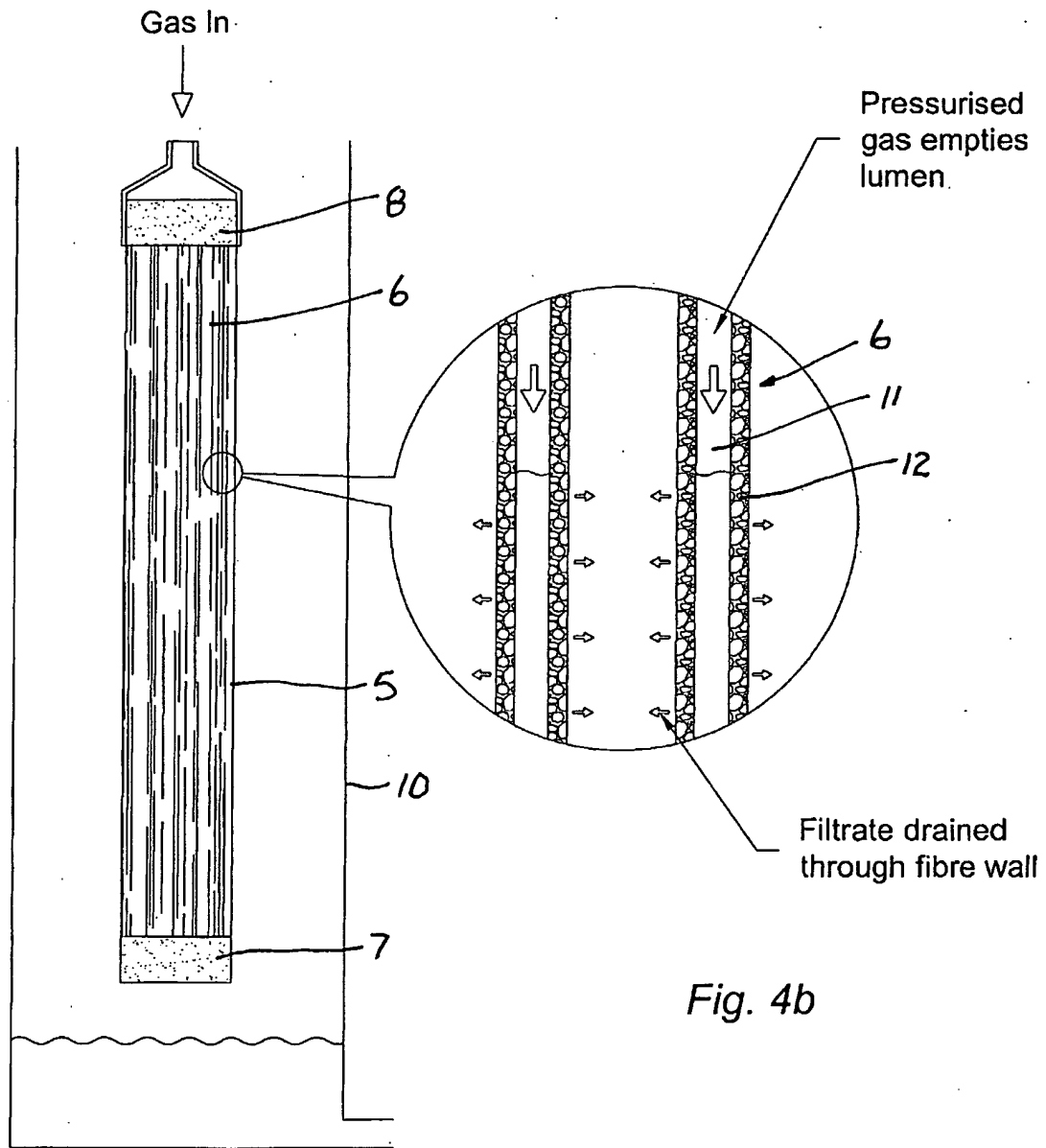

Fig. 4a

Fig. 4b

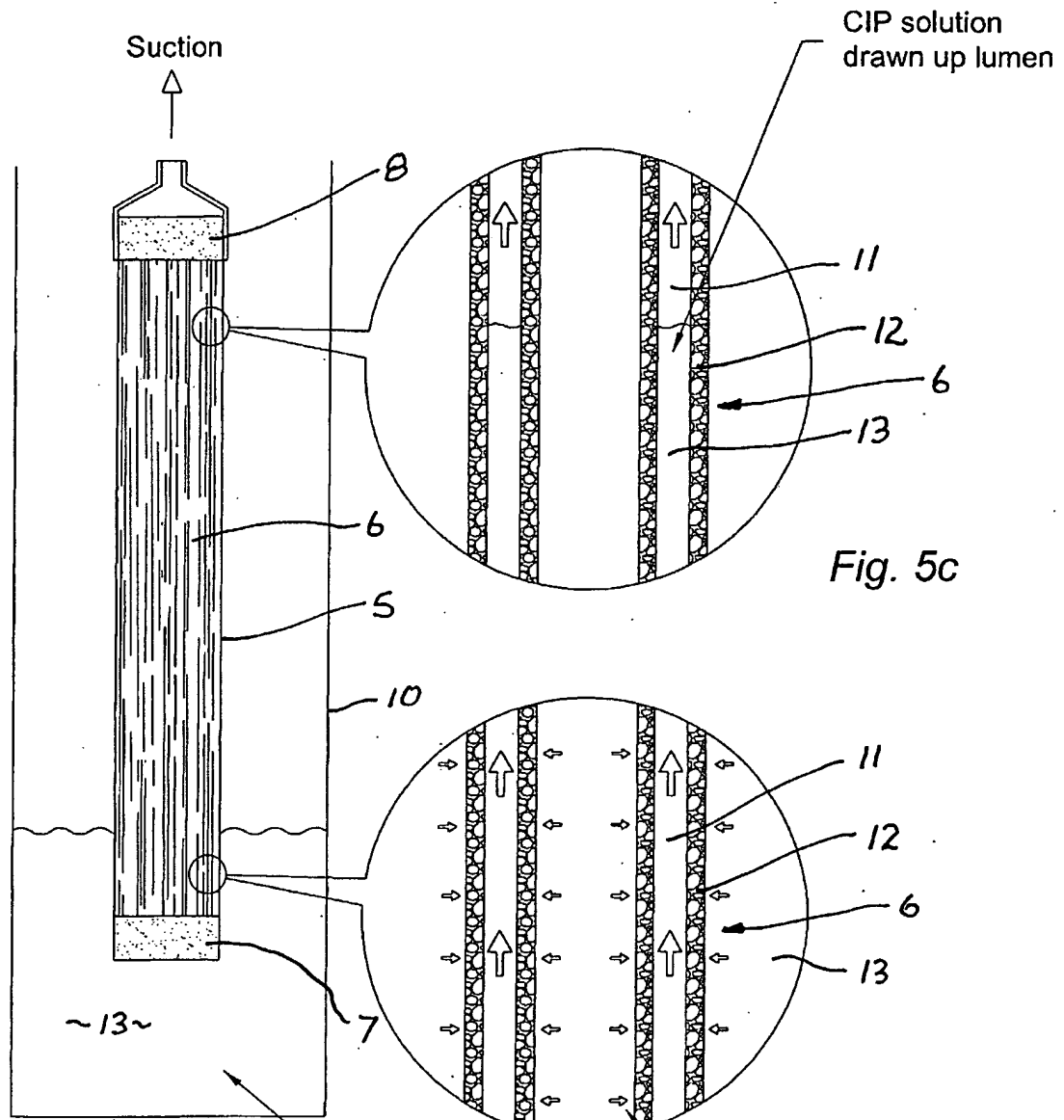

Fig. 5a

Fig. 5b

CIP solution drawn through fibre wall and carried up lumen

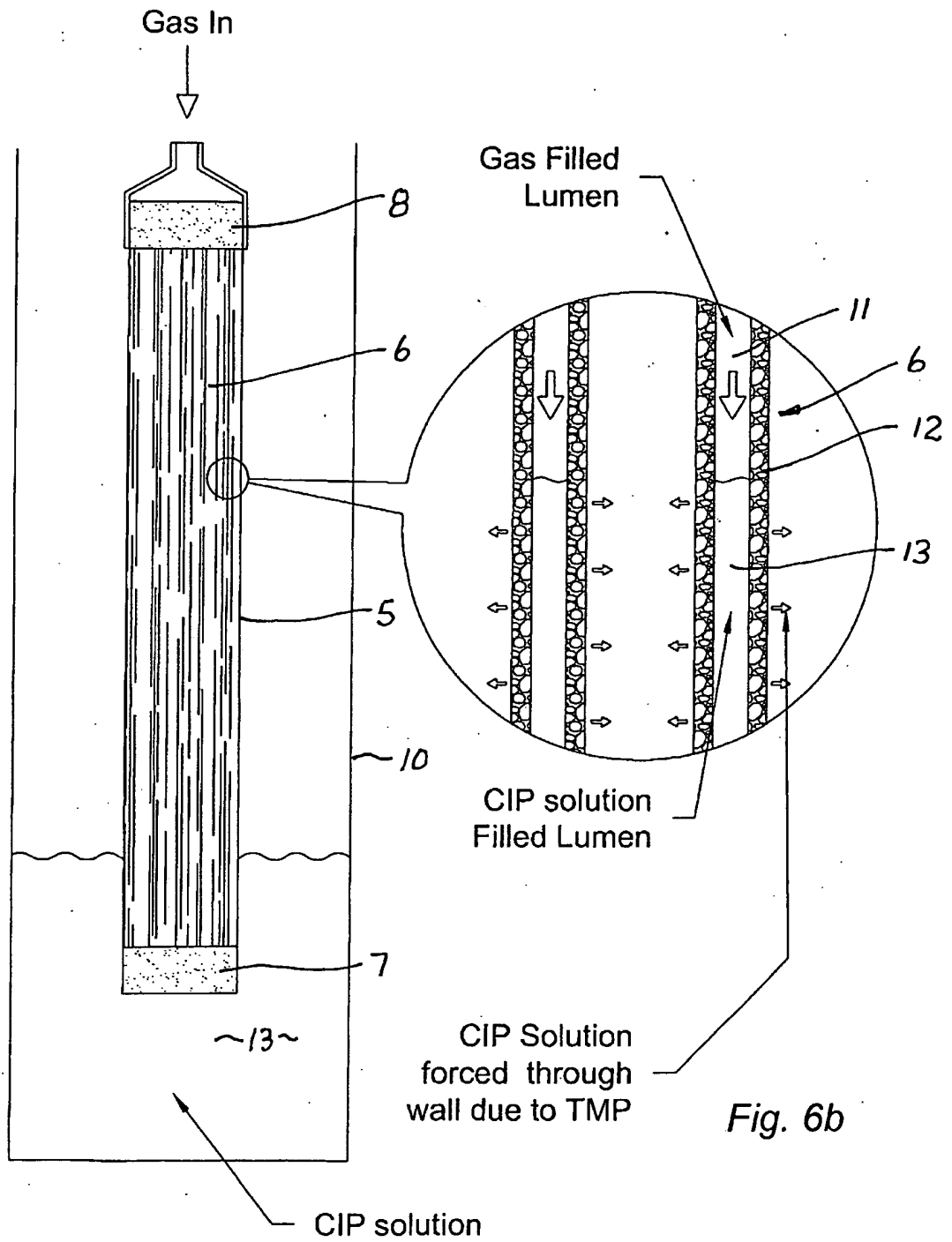

Fig. 6a

Fig. 6b

INTERNATIONAL SEARCH REPORT

International application No.

PCT/AU2004/001292

A. CLASSIFICATION OF SUBJECT MATTER		
Int. Cl. ⁷ : B01D 65/02		
According to International Patent Classification (IPC) or to both national classification and IPC		
B. FIELDS SEARCHED		
Minimum documentation searched (classification system followed by classification symbols)		
Documentation searched other than minimum documentation to the extent that such documents are included in the fields searched		
Electronic data base consulted during the international search (name of data base and, where practicable, search terms used) Derwent DWPI: IPC + Keywords AERAT, BUBBL, BACKWASH, BACKFLUSH		
C. DOCUMENTS CONSIDERED TO BE RELEVANT		
Category*	Citation of document, with indication, where appropriate, of the relevant passages	Relevant to claim No.
X	WO 1993/002779 A1 (MEMTEC LIMITED) 18 February 1993 Page 6 lines 4-11	2-4,11-13
X	US 4767539 A (FORD) 30 August 1988 Abstract, claims	2,3,12,13
X	GB 2120952 A (JGC CORPORATION) 14 December 1983 Claims	2,3,11-13
X	Derwent Abstract Accession No. 98-162733/15, Class J01, JP 10028845 A (KANEBUCHI KAGAKU KOGYO KK) 3 February 1998	2,3,12,13
<input checked="" type="checkbox"/> Further documents are listed in the continuation of Box C		<input checked="" type="checkbox"/> See patent family annex
* Special categories of cited documents:		
"A" document defining the general state of the art which is not considered to be of particular relevance	"T" later document published after the international filing date or priority date and not in conflict with the application but cited to understand the principle or theory underlying the invention	
"E" earlier application or patent but published on or after the international filing date	"X" document of particular relevance; the claimed invention cannot be considered novel or cannot be considered to involve an inventive step when the document is taken alone	
"L" document which may throw doubts on priority claim(s) or which is cited to establish the publication date of another citation or other special reason (as specified)	"Y" document of particular relevance; the claimed invention cannot be considered to involve an inventive step when the document is combined with one or more other such documents, such combination being obvious to a person skilled in the art	
"O" document referring to an oral disclosure, use, exhibition or other means	"&" document member of the same patent family	
"P" document published prior to the international filing date but later than the priority date claimed		
Date of the actual completion of the international search 26 November 2004	Date of mailing of the international search report 13 DEC 2004	
Name and mailing address of the ISA/AU AUSTRALIAN PATENT OFFICE PO BOX 200, WODEN ACT 2606, AUSTRALIA E-mail address: pct@ipaustrialia.gov.au Facsimile No. (02) 6285 3929	Authorized officer MATTHEW FRANCIS Telephone No : (02) 6283 2424	

INTERNATIONAL SEARCH REPORT

International application No.
PCT/AU2004/001292

C (Continuation). DOCUMENTS CONSIDERED TO BE RELEVANT		
Category*	Citation of document, with indication, where appropriate, of the relevant passages	Relevant to claim No.
X	Derwent Abstract Accession No. 85-064514/11, Class J01, JP 60019002 A (NIPPON GENSHIRYOKU JUIGYO) 31 January 1985	2

INTERNATIONAL SEARCH REPORT

International application No.

PCT/AU2004/001292

This Annex lists the known "A" publication level patent family members relating to the patent documents cited in the above-mentioned international search report. The Australian Patent Office is in no way liable for these particulars which are merely given for the purpose of information.

Patent Document Cited in Search Report		Patent Family Member					
WO	9302779	AU	24220/92	AU	62042/96	AU	94068/98
		CA	2114228	EP	0641246	US	5643455
US	4767539	AU	34400/84	EP	0160014	WO	8501449
GB	2120952	FR	2525488	JP	58183906	JP	58183916
		US	4540490				
JP	10028845	NIL					
JP	60019002	NIL					
<p>Due to data integration issues this family listing may not include 10 digit Australian applications filed since May 2001.</p> <p style="text-align: right;">END OF ANNEX</p>							